

MEASURING INSTRUMENT

TEMPERATURE, PRESSURE, FLOW

ME-402

Prepared By: Prof.Sachin kumar Nikam
Assistant Professor
Department of Mechanical,
L.N.C.T , Bhopal

Temperature & Measuring Instruments

Temperature definition is - degree of hotness or coldness measured on a definite scale

Three temperature scales are in general use today. The Fahrenheit ($^{\circ}\text{F}$) temperature scale is used in the United States and a few other English-speaking countries. The Celsius ($^{\circ}\text{C}$) temperature scale is standard in virtually all countries that have adopted the metric system of measurement, and it is widely used in the sciences. The Kelvin (K) scale, an absolute temperature scale (obtained by shifting the Celsius scale by -273.15° so that absolute zero coincides with 0 K), is recognized as the international standard for scientific temperature measurement.

Thermometric property

The property of a substance which changes uniformly with the uniform change in temperature is known as thermometric property

Thermometer	Thermometric property
Constant vol. gas thermometer	Pressure
Constant pressure gas thermometer	Volume
Electrical Resistance Thermometer	Resistance
Thermocouple	Thermal e.m.f
Mercury in glass thermometer	Length

DIFFERENT TYPES OF TEMPERATURE MEASURING DEVICES

Following are the most commonly used temperature measuring devices.

- Liquid in Glass Thermometer
- Electric Resistance Thermometer
 - Radiation Thermometry
 - Thermocouple
 - Silicon Diode
 - Bimetallic Devices
 - Bulb and Capillary Sensor
 - Constant volume Gas Thermometer
 - Sealed Bellows
- Constant Pressure Gas Thermometer

Liquid-in-Glass Thermometer

The Liquid-in-Glass Thermometer is a type of a thermometer used to measure temperature. The thermal expansion of the liquid is the principle used to measure the temperature in the thermometer. When the temperature increases, the liquid expands and then rises in the capillary tube in the thermometer.

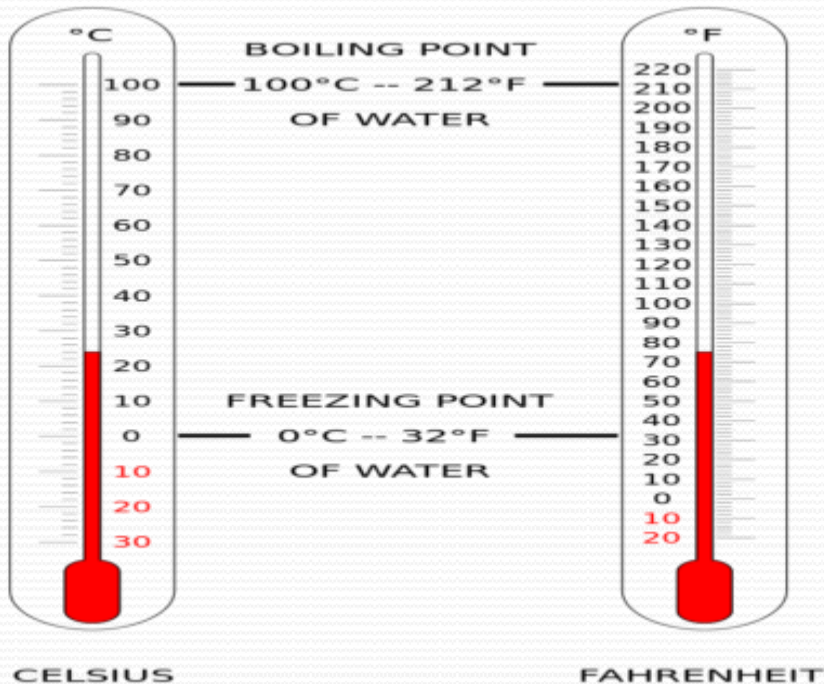
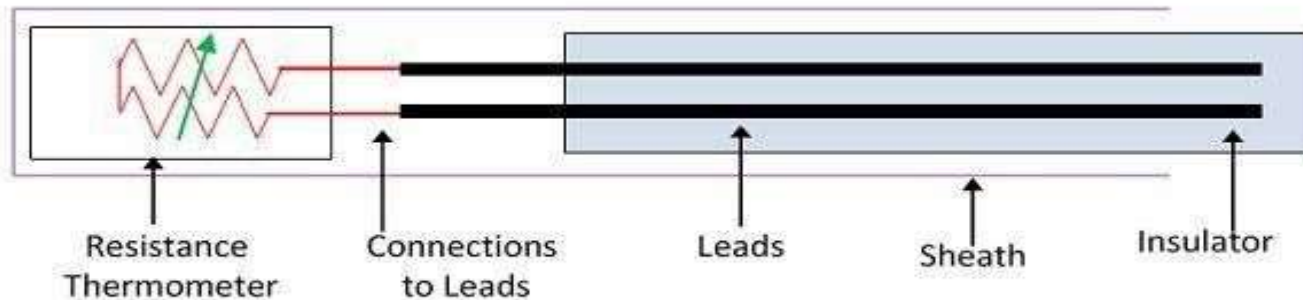

Table : Types of thermometric liquids.

Liquid	Temperature range, °C	
	From	To
Mercury	-35	750
Toluene	-90	200
Ethanol	-80	70
Kerosene	-60	300
Petroleum Ether	-120	25
Pentane	-200	20

Resistance thermometers

Resistance thermometers, also called resistance temperature detectors (RTDs), are sensors used to measure temperature. Many RTD elements consist of a length of fine wire wrapped around a ceramic or glass core but other constructions are also used. The RTD wire is a pure material, typically platinum, nickel, or copper. The material has an accurate resistance/temperature relationship which is used to provide an indication of temperature. As RTD elements are fragile, they are often housed in protective probes.



Resistance Thermometer

➔ Advantages and limitations

The advantages of platinum resistance thermometers include:

1. High accuracy
2. Low drift
3. Wide operating range
4. Suitability for precision applications.

Limitations:

RTDs in industrial applications are rarely used above 660 °C. At temperatures above 660 °C it becomes increasingly difficult to prevent the platinum from becoming contaminated by impurities from the metal sheath of the thermometer. This is why laboratory standard thermometers replace the metal sheath with a glass construction. At very low temperatures, say below -270 °C (3 K), because there are very few phonons, the resistance of an RTD is mainly determined by impurities and boundary scattering and thus basically independent of temperature. As a result, the sensitivity of the RTD is essentially zero and therefore not useful.



Thermocouple

*A **Thermocouple** is a sensor used to measure temperature. **Thermocouples** consist of two wire legs made from different metals. The wires legs are welded together at one end, creating a junction. This junction is where the temperature is measured. When the junction experiences a change in temperature, a voltage is created.*

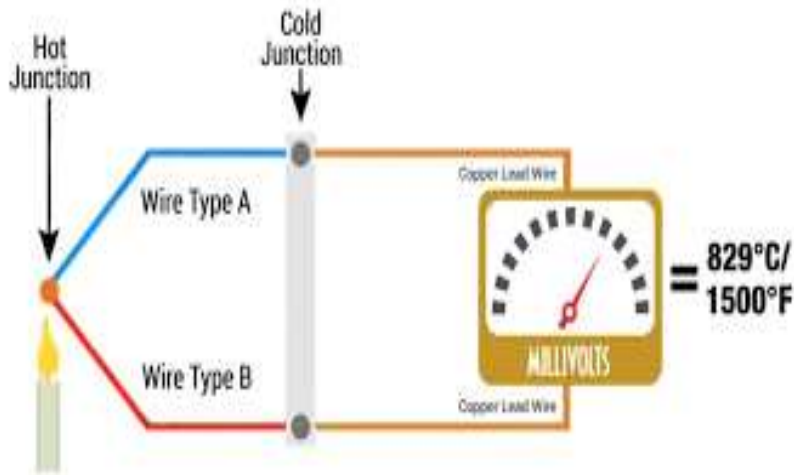

THERMOCOUPLE TABLE

ANSI Code	ANSI MC 96.1 Colour Coding		Alloy Combination		IEC 584-3 Colour Coding		IEC Code
	Thermocouple Grade	Extension Grade	+ Lead	- Lead	Thermocouple Grade	Intrinsically Safe	
J			IRON Fe (magnetic)	CONSTANTAN COPPER-NICKEL Cu-Ni			J
K			CHROME-GA* NICKEL- CHROMIUM Ni-Cr	ALOMEGA* NICKEL-ALUMINUM Ni-Al (magnetic)			K
T			COPPER Cu	CONSTANTAN COPPER-NICKEL Cu-Ni			T
E			CHROME-GA* NICKEL- CHROMIUM Ni-Cr	CONSTANTAN COPPER-NICKEL Cu-Ni			E
N			OMEGA-P* NICROSIL Ni-Cr-Si	OMEGA-N* NISIL Ni-Si-Mg			N
R	NONE ESTABLISHED		PLATINUM- 13% RHODIUM Pt-13% Rh	PLATINUM Pt			R
S	NONE ESTABLISHED		PLATINUM- 10% RHODIUM Pt-10% Rh	PLATINUM Pt			S
U	NONE ESTABLISHED		COPPER Cu	COPPER-LOW NICKEL Cu-Ni			U
B	NONE ESTABLISHED		PLATINUM- 30% RHODIUM Pt-30% Rh	PLATINUM- 6% RHODIUM Pt-6% Rh			B
G* (W)	NONE ESTABLISHED		TUNGSTEN W	TUNGSTEN- 26% RHENIUM W-26% Re	NO STANDARD USE ANSI COLOUR CODE		G (W)
C* (W5)	NONE ESTABLISHED		TUNGSTEN- 5% RHENIUM W-5% Re	TUNGSTEN- 26% RHENIUM W-26% Re	NO STANDARD USE ANSI COLOUR CODE		C (W5)
D* (W3)	NONE ESTABLISHED		TUNGSTEN- 3% RHENIUM W-3% Re	TUNGSTEN- 25% RHENIUM W-25% Re	NO STANDARD USE ANSI COLOUR CODE		D (W3)

* Not official symbol or standard designation

Pyrometer

*A **pyrometer** is a type of remote-sensing thermometer used to measure the temperature of a surface it is a device that from a distance determines the temperature of a surface from the amount of the thermal radiation it emits, a process known as pyrometry and sometimes radiometry.*

Pyrometer are two types

- ✓ Optical Pyrometer
- ✓ Radiation pyrometer



✓ Optical Pyrometer

Optical Pyrometer. Definition: The **optical pyrometer** is a non-contact type temperature measuring device. It works on the principle of matching the brightness of an object to the brightness of the filament which is placed inside the **pyrometer**.

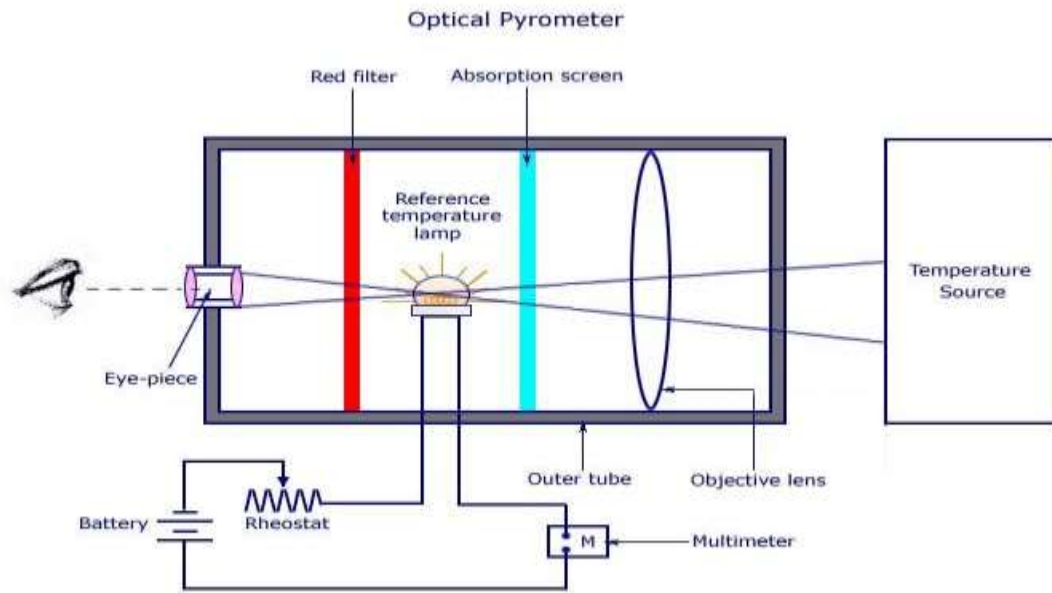

www.InstrumentationToday.com

Optical Pyrometer - Temperature Measurement

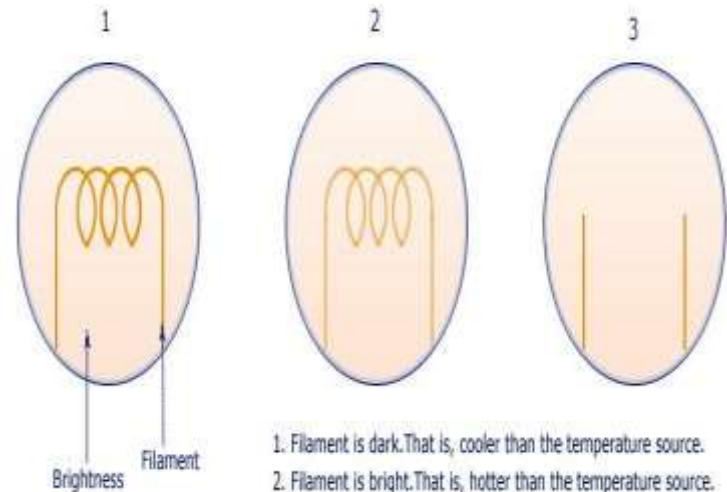

1. Filament is dark. That is, cooler than the temperature source.
2. Filament is bright. That is, hotter than the temperature source.
3. Filament disappears. Thus, equal brightness between filament and temperature source.

www.InstrumentationToday.com



✓ Radiation Pyrometer

They are non-contact devices, used to measure temperature above 1500 degree Celsius, contact devices may melt at this temperature The heat energy emitted from the hot body is allowed passed on to the lens. Which collects it and focused on to the detector with the mirror and eyepiece arrangement. Now the detector converts the radiation energy into an electrical signal. Thermopiles and photon multipliers are commonly used detectors. Detectors produce the reading and shows in the temperature display.

Advantages:

- Low cost
- N need of contact
- Fast response speed

Disadvantages:

- Emissive error are introduced
- Error due to the absorption of the radiation by the carbon dioxide , water or other apparently transparent gases

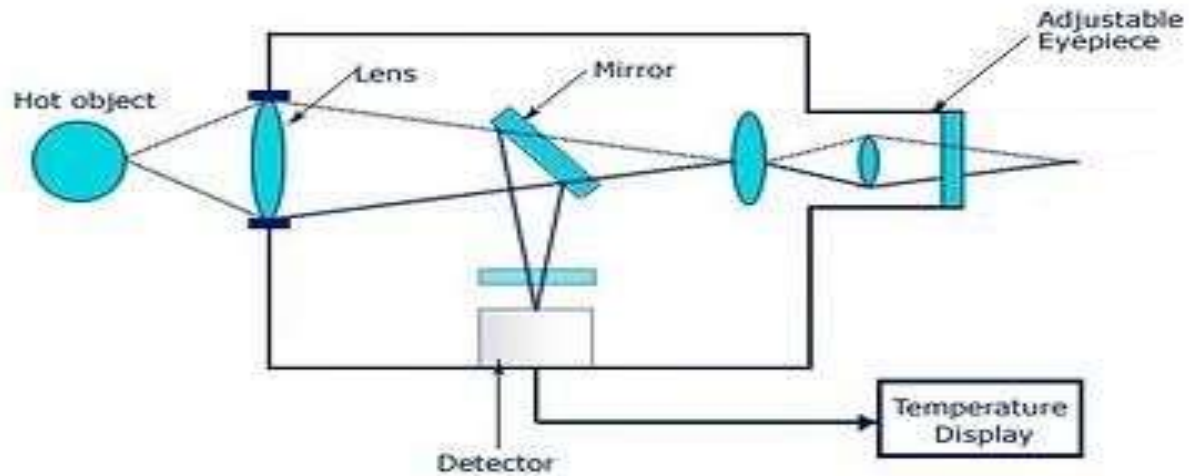

✓ Radiation Pyrometer

Bimetallic thermometers

Bimetallic thermometers are made up of bimetallic strips formed by joining two different metals having different thermal expansion coefficients. Basically, bimetallic strip is a mechanical element which can sense temperature and transform it into a mechanical displacement.

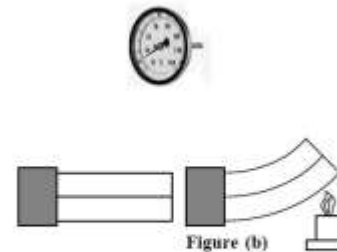
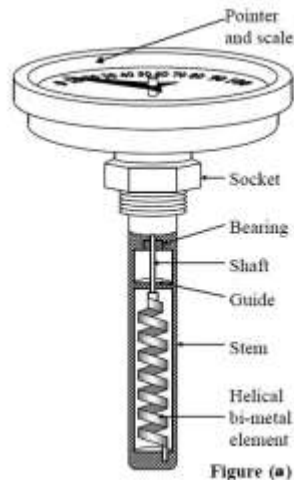
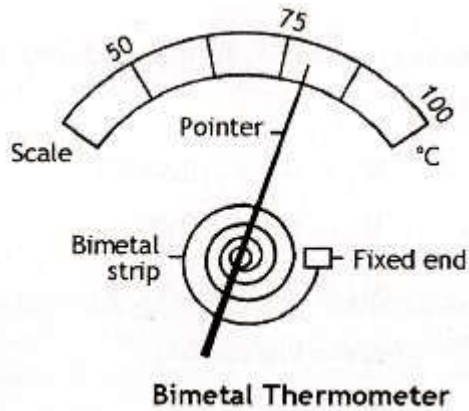

Constant Volume Gas Thermometer

Constant Volume Gas Thermometer: A constant volume gas thermometer usually consists of a bulb filled with a fixed amount of a dilute gas which is attached to a mercury manometer. The manometer is used to measure variation in pressure. This thermometer works on the principle of Law of Gay-Lussac.

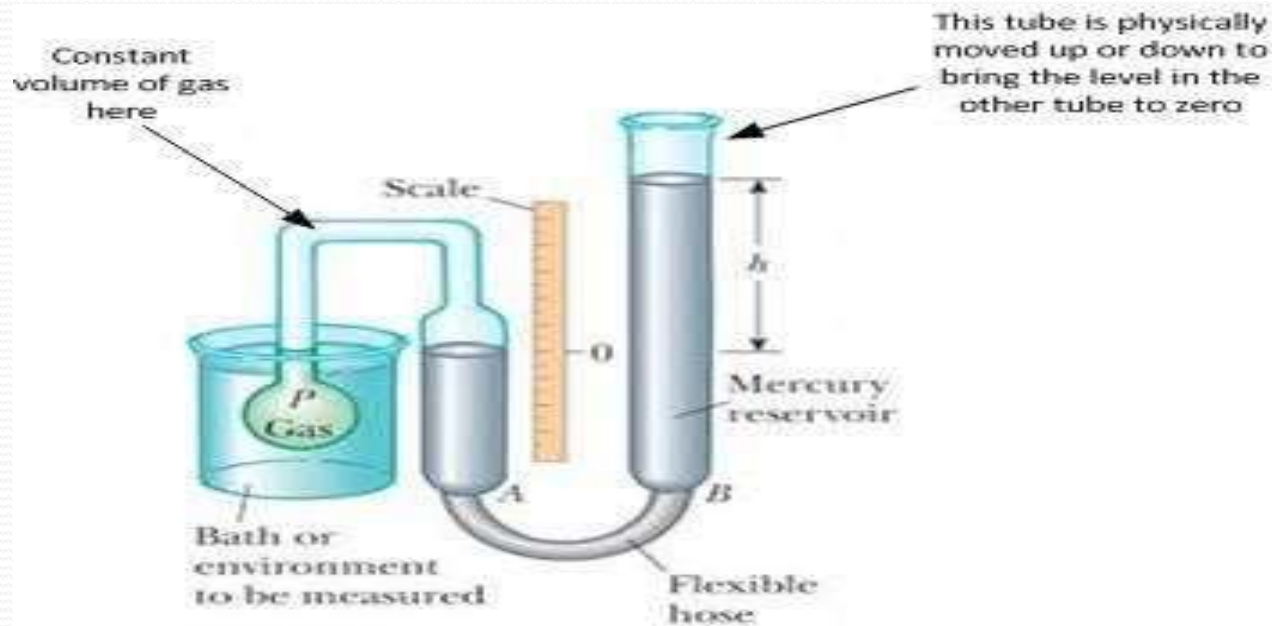



PRESSURE MEASURING DEVICES

Pressure Measurement

Pressure is defined as the physical force exerted on an object. The force applied is perpendicular to the surface of objects per unit area.

The basic formula for pressure is F/A (Force per unit area).

Unit of pressure is Pascals (Pa).

Types of Pressures are Absolute, Atmospheric, Differential, and Gauge Pressure.

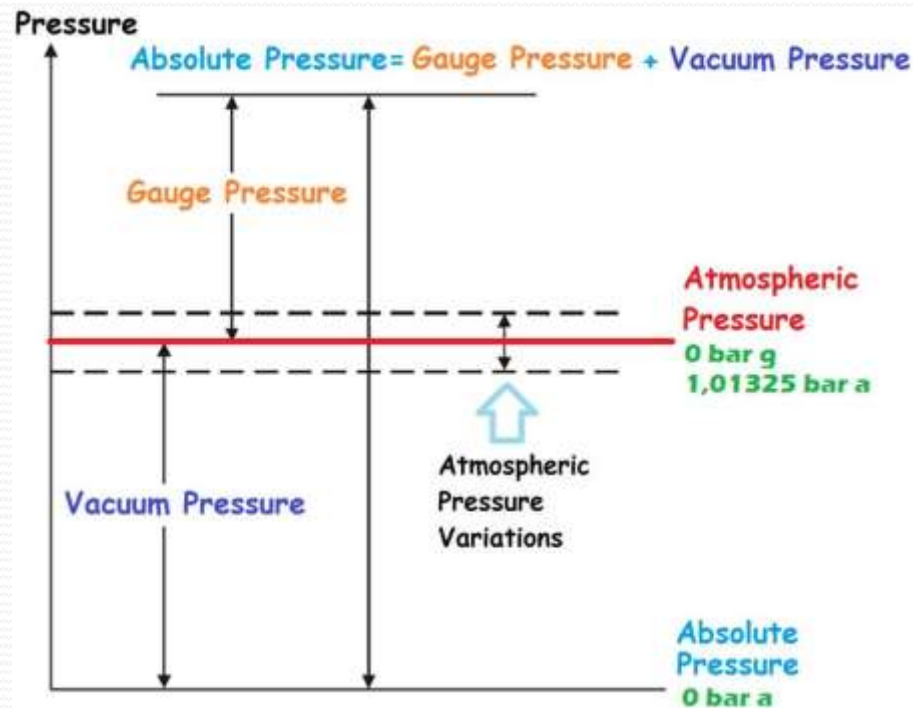

Pressure measuring instruments

Classification of pressure measuring instruments based on construction and working principles

Liquid column elements:

Elastic element gauge:

Electrical transducers:

Force -balanced devices



Liquid column elements:

Barometer

Manometer -u tube,

BAROMETER:

The barometer is used to measure atmospheric pressure. Atmospheric pressure is the pressure exerted by the air surrounding the earth that goes on decreasing away from the earth surface.

Working principle:

Barometric liquid balances the atmospheric pressure against vacuum and pressure head reading is obtained in the absolute units.

Construction and working:

The barometer has a glass tube closed at one end and opened at the other; the length of the tube must be greater than 76.2 cm. the tube is first completely filled with mercury and the open end is temporarily plugged. Then the tube is inverted so that plugged end is immersed in a mercury pan. When the plug is removed, the mercury in the tube drops by a certain amount, creating a vacuum at the top of the tube and then reading 'h' is noted. The reading 'h' is proportional to atmospheric pressure acting on mercury in the pan. Note that this atmospheric pressure reading is in absolute units.

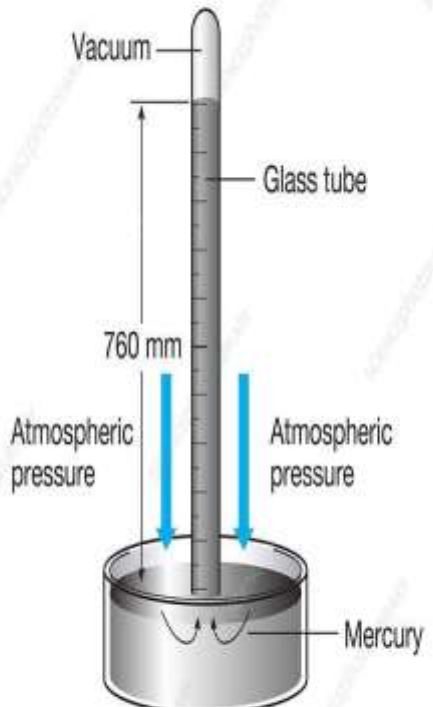

Manometer –u tube

*The device used to know about the pressure difference in the pipeline, it is simple in construction, the basic law of physics is applied for calculation of the pressure drop. It is a glass or metal tube with a 'U' bend providing with two legs. Manometric fluids as mercury or carbon tetrachloride etc., where the density should be higher than the fluid which flows through the pipe, manometric fluid will be filled in the tube for the value, the two legs are connected to the points on which we are interested to calculate the **differential pressure**, when this done the fluid which flows in the pipe or tube will enter into both the legs, the pressure on the leg will differ showing the deflection of height in the manometric fluid.*

Principle: all manometers work on the effect of the hydrostatic pressure exerted by a liquid column. In manometer unknown pressure is determined by balancing it against some known pressure or vacuum.

Construction and working: The U-tube manometer consists of glass U-tube partially filled with a suitable liquid like water, mercury etc. one of the arms or legs of the manometer, is connected to unknown pressure tap to be measured while other is connected to other pressure tap or it is left open to atmosphere.

When there is a difference of pressure between two arms of the manometer, liquid levels in the two arms of the manometer, liquid levels in the two arms do not match. This level difference in the two arms of the manometer represents differential pressure ($P_1 - P_2$). The static balance equation is

$$P_2 - P_1 = h \rho g$$

h = height difference, ρ = mass density of manometer liquid

If the fluid over manometer liquid has appreciable density, then static balance equation can be written as:

$$P_2 - P_1 = h (\rho_m - \rho_l) g$$

h = height difference, ρ_m = mass density of manometric liquid, ρ_l = mass density of fluid over manometric liquid

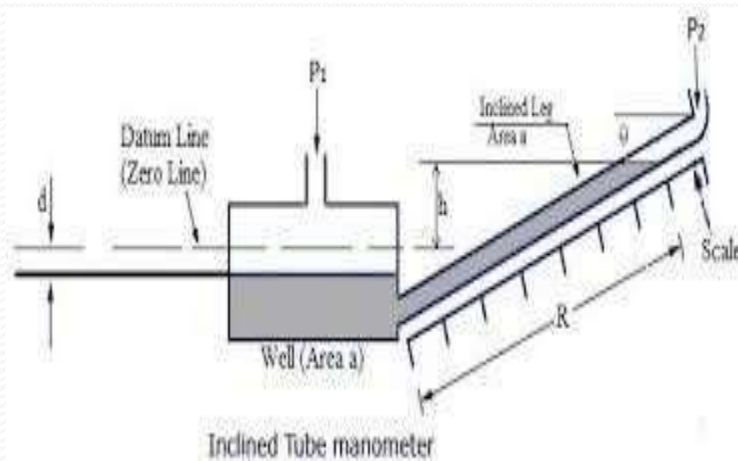
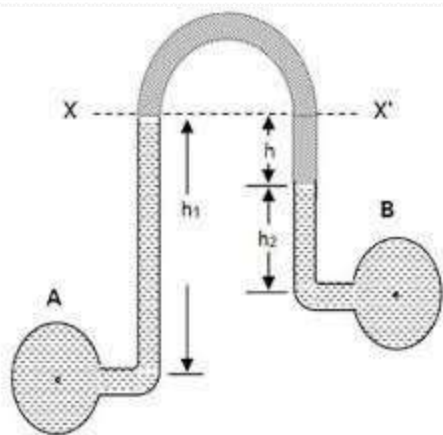
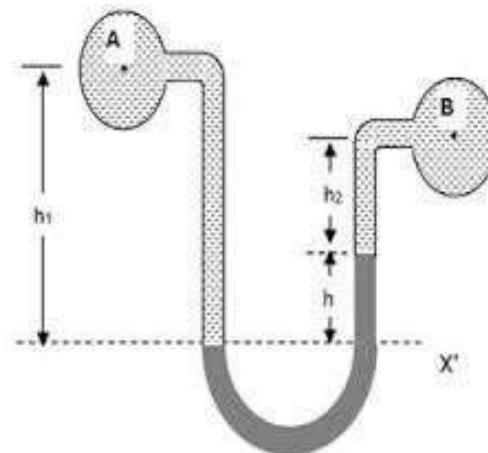
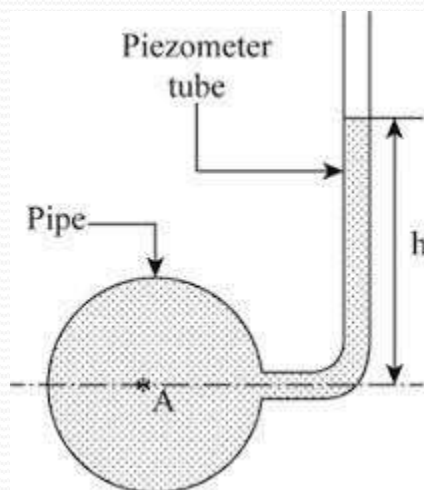
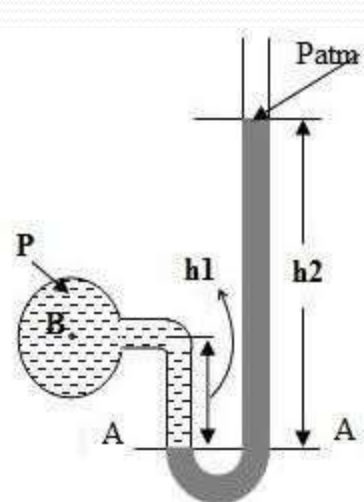

INCLINED –LEG MANOMETER:

The construction is very similar to enlarged leg manometer except that small diameter tube is inclined to the vertical axis.

When pressure P_1 and P_2 are applied then liquid rises in the tube, the level of manometric liquid inside the tube is measured from zero level along the inclined tube which represents the differential pressure ($P_1 - P_2$) the static balance equation can be written as

$$P_2 - P_1 = \rho d \sin \alpha [1 + (A_1/A_2)]$$

α = angle of inclination of the inclined leg

d = height difference measured

Advantages:

Due to inclined leg, the manometer reading gets amplified. Hence it can be used for measurement of low pressures of which cannot be measured by other manometers. By reducing angle α , the scale length and hence the sensitivity can be increased.





MANOMETRIC LIQUIDS:

Desirable properties of good manometric liquid should have:-

Low-freezing point

High boiling point

Non-wetting characteristics

Low surface tension

Chemically inert

Clear visible interface

Ability to maintain density at various temperatures

MANOMETRIC FLUIDS USED IN PRACTICE ARE:

Mercury: Mercury has a low freezing point (-38F) and high boiling point (675F) but it corrodes many metals and it is poisonous and expensive.

Water with coloring agents: color agents reduce the surface tension of pure water, that reduce the capillarity effect in the manometer.

Benzene, Kerosene, CCl_4 , toluene etc.. to make CCl_4 visible a few iodine crystals can be added.



Advantages and limitations:

Advantages:

- Simple inexpensive construction
- High accuracy and sensitivity
- Can be used for low-pressure measurements
- The desired span can be obtained just by using suitable manometric liquids
- Pressure range of manometers is 3 to 100 KPa.

Limitations:

- ❖ No over range protection
- ❖ Requires large space
- ❖ Non-portable
- ❖ Levelling is required
- ❖ Condensation of test liquid affects the reading.

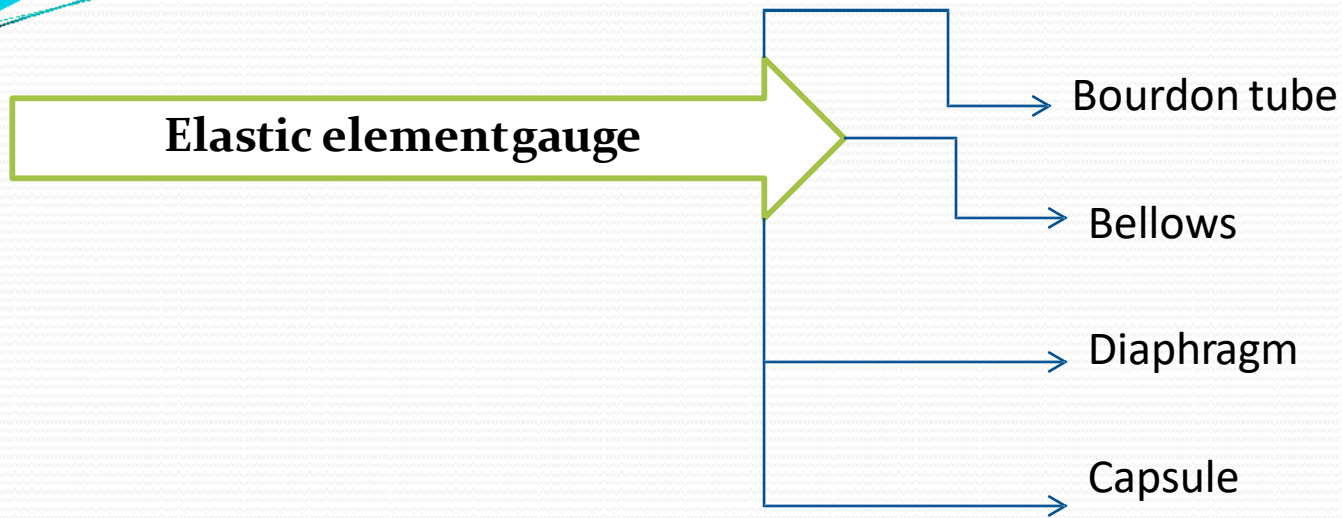

Transducers are a device that converts one form of energy into some other form. These pressure gauges have an elastic element that converts pressure signal into proportional mechanical displacement. In this article, we study Bourdon gauge, bellow gauge, diaphragm gauge and capsule gauge.

Bourdon tube

A bourdon tube is a curved, hollow tube with the process pressure applied to the fluid in the tube. The pressure in the tube causes the tube to deform or uncoil. The pressure can be determined from the mechanical displacement of the pointer connected to the bourdon tube. The Bourdon pressure gauge operates on the principle that, when pressurized, a flattened tube tends to straighten or regain its circular form in cross-section. ... When a gauge is pressurized, the Bourdon creates the dial tip travel to enable pressure measurement

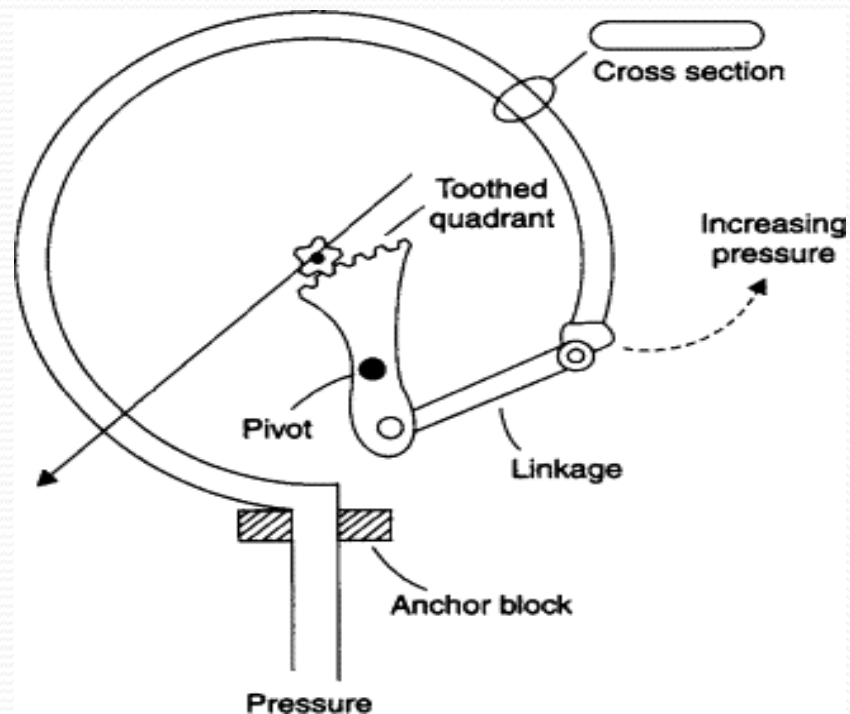

Advantages and limitations:

Advantages of Bourdon tube pressure gauge:

- ✓ These Bourdon tube pressure gauges give accurate results.
- ✓ Bourdon tube cost low.
- ✓ Bourdon tube are simple in construction.
- ✓ They can be modified to give electrical outputs.
- ✓ They are safe even for high pressure measurement.
- ✓ Accuracy is high especially at high pressures.

Limitations of bourdon tube pressure gauge:

- ❖ They respond slowly to changes in pressure
- ❖ They are subjected to hysteresis.
- ❖ They are sensitive to shocks and vibrations.
- ❖ Amplification is a must as the displacement of the free end of the bourdon tube is low.
- ❖ It cannot be used for precision measurement.

Bellows Pressure Gauge

Bellows are thin-walled metallic cylinders, with deep convolutions, of which one end is sealed and the other end remains open. The closed end can move freely while the open end is fixed. When pressure is applied to the closed end, such as in the animation below, the bellows will be compressed. The closed end will move upwards and the link, which is the rod in between the closed end of the bellows and the transmission mechanism, will go up and rotate the pointer.

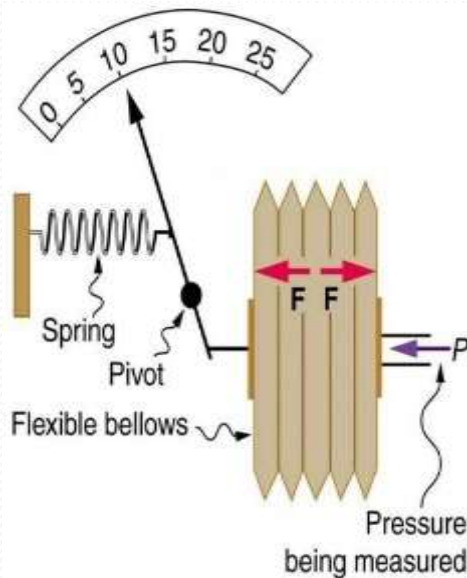

ADVANTAGE:

- ✓ It is used to measure absolute & differential pressure.
- ✓ It is used to measure low or medium pressure range.

DISADVANTAGE :

- ❖ It is not useful to measure high value pressure.
- ❖ Bellows joints can fail catastrophically.
- ❖ Not in place maintenance or repair can be performed – they must be replaced if damaged.

Diaphragm Pressure Gauge

*Diaphragm pressure gauges are used to measure gases and liquids. ... The measuring element consists of one circular **diaphragm** clamped between a pair of flanges. The positive or negative pressure acting on these **diaphragms** causes deformation of the measuring element.*

Diaphragm pressure gauges Advantages:

- ✓ Excellent load performance
- ✓ Linearity
- ✓ Suitable for measuring absolute pressure, differential pressure
- ✓ Small size, affordable
- ✓ Can be used for viscous, slurry measurement.

Diaphragm pressure gauge Disadvantages:

- ❖ Seismic, impact resistance is not good
- ❖ Difficulty in maintenance
- ❖ Lower measurement pressure

Applications of the diaphragm pressure gauge:-

For measuring points with increased overload
With liquid-filled case suitability for high dynamic pressure loads and vibrations For gaseous, liquid and aggressive media, also in aggressive environments With the open connecting flange option also for contaminated and viscous media

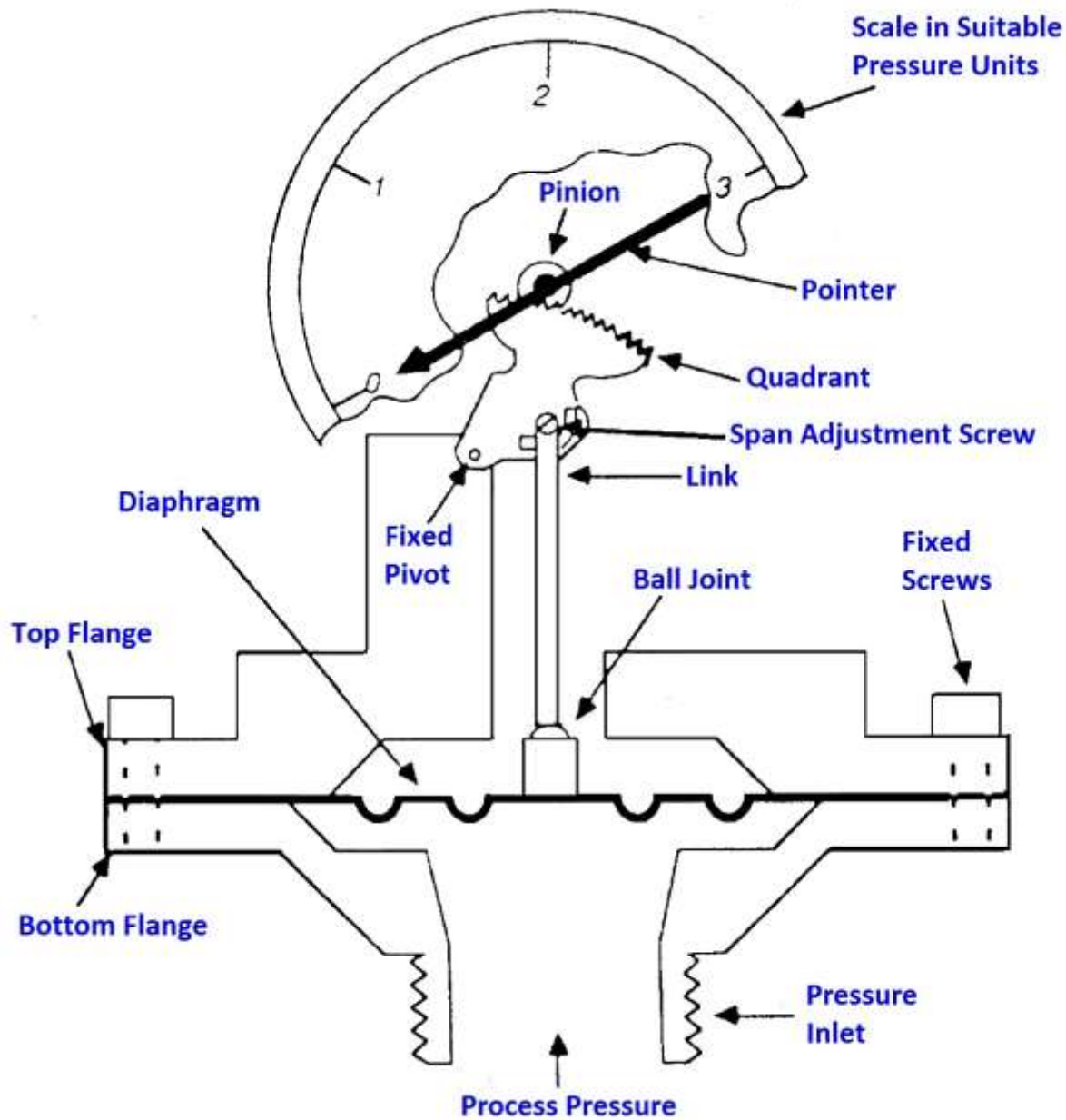

Electrical transducers:

Resistance-Type Transducers

Resistance-Type Transducers

A strain gauge measures the external force (**pressure**) applied to a fine wire. The fine wire is usually arranged in the form of a grid. The **pressure** change causes a **resistance** change due to the distortion of the wire.

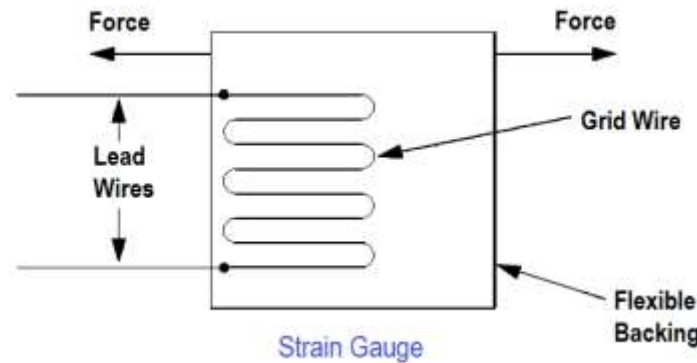

$$R = \rho \frac{L}{A}$$

R = resistance of the wire grid in ohms

ρ = resistivity constant for the particular type of wire grid

L = length of wire grid

A = cross sectional area of wire grid

As the wire grid is distorted by elastic deformation, its length is increased, and its cross-sectional area decreases. These changes cause an increase in the resistance of the wire of the strain gauge. This change in resistance is used as the variable resistance in a bridge circuit that provides an electrical signal for indication of pressure. Figure 2 illustrates a strain gauge pressure transducer.

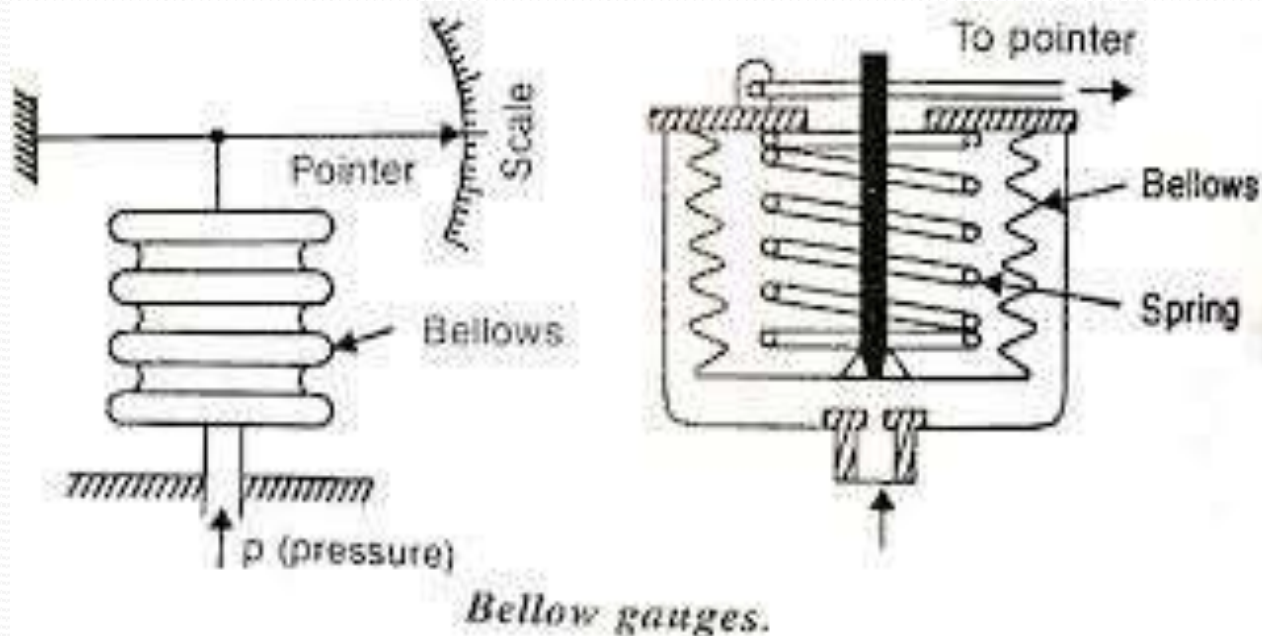

Inductance Type Pressure

Inductance Type Pressure Transducers Principle. The **inductance-type** transducer consists of three parts: a coil, a movable magnetic core, and a **pressure** sensing element. The element is attached to the core, and, as **pressure** varies, the element causes the core to move inside the coil.

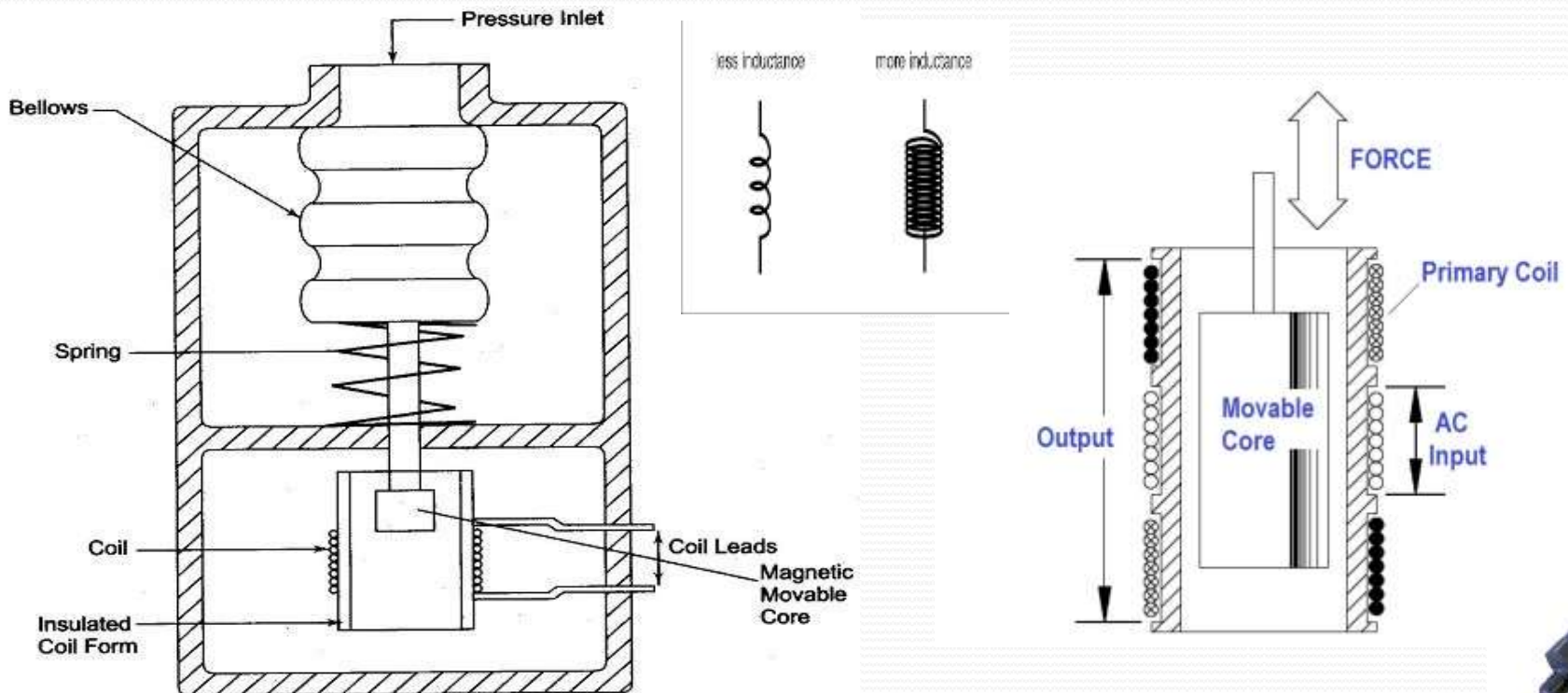

Fig. 13.22 Pressure Inductive Transducer

Force -balanced devices

dead weight tester

A **dead weight tester** is an instrument that calibrates pressure by determining the **weight** of force divided by the area the force is applied. The formula for **dead weight testers** is pressure equals force divided by area of where force is applied

Dead weight testers are used to measure the pressure exerted by gas or liquid and can also generate a test pressure for the calibration of numerous pressure instruments.

In dead weight tester, we put the weight on the weight stand of dead weight tester putting weight is reference weight which is to be calibrate and further we applied pressure by moving piston ,when applied pressure and reference weight(Pressure)is equal at this condition reference weight will be zero(Dead). Therefore it is called dead weigh tester.

A deadweight tester (DWT) is a calibration standard which uses a piston cylinder on which a load is placed to make an equilibrium with an applied pressure underneath the piston.

The formula to design a DWT is based basically is expressed as follows :

$$p = F / A \quad [\text{Pa}]$$

Where:

p: reference pressure [Pa]

F : force applied on piston [N]

A : effective area PCU [m²]

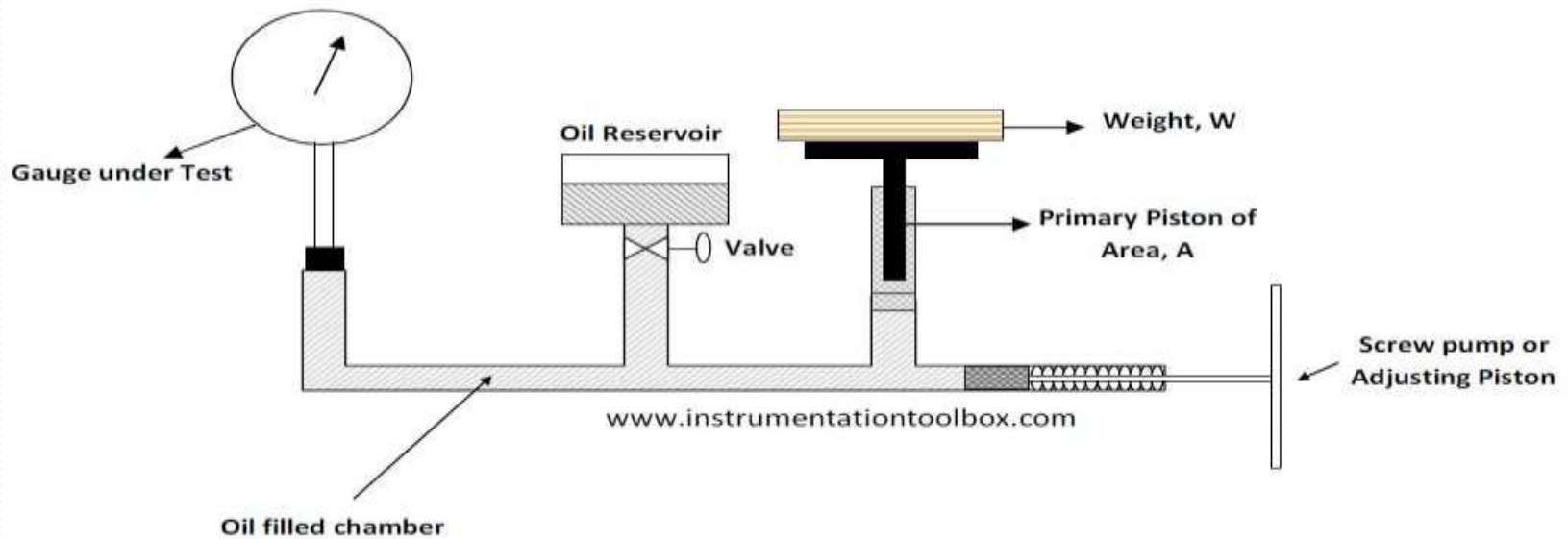
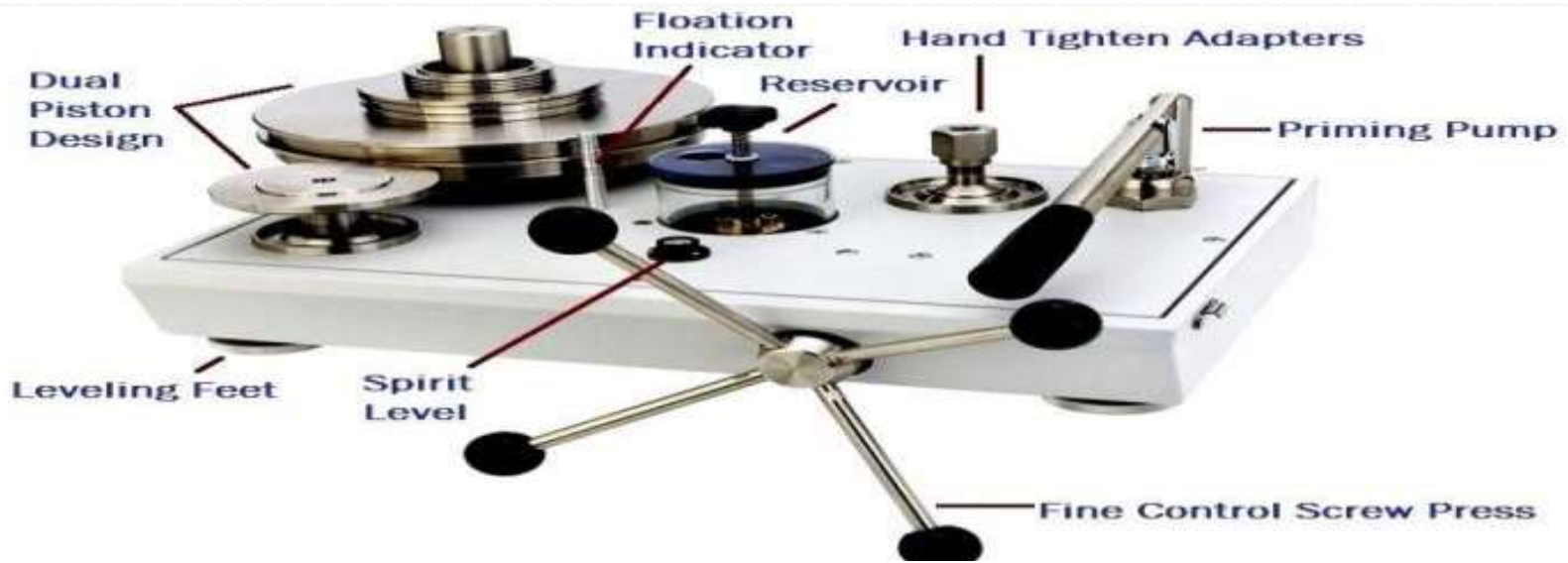

FLOW MEASUREMENT

Flow measurement is the quantification of bulk fluid movement.

A **flow meter** is a **device** used to **measure** the volume or mass of a gas or liquid.

There are two forms of measurement typically used: volume and mass. The devices used to measure the mass or volumetric flow rate of a liquid or gas include mechanical flow meters, differential pressure-based meters, variable area meters, electromagnetic flow meters, thermal mass flow meters,

Different types of fluid flow meters–

- ✓ Orifices,
- ✓ Venturies,
- ✓ Nozzles,
- ✓ Rotameters,
- ✓ Pitot Tubes,
- ✓ Calorimetrics,
- ✓ Turbine,
- ✓ Vortex,
- ✓ Electromagnetic, Doppler, Ultrasonic, Thermal, Coriolis

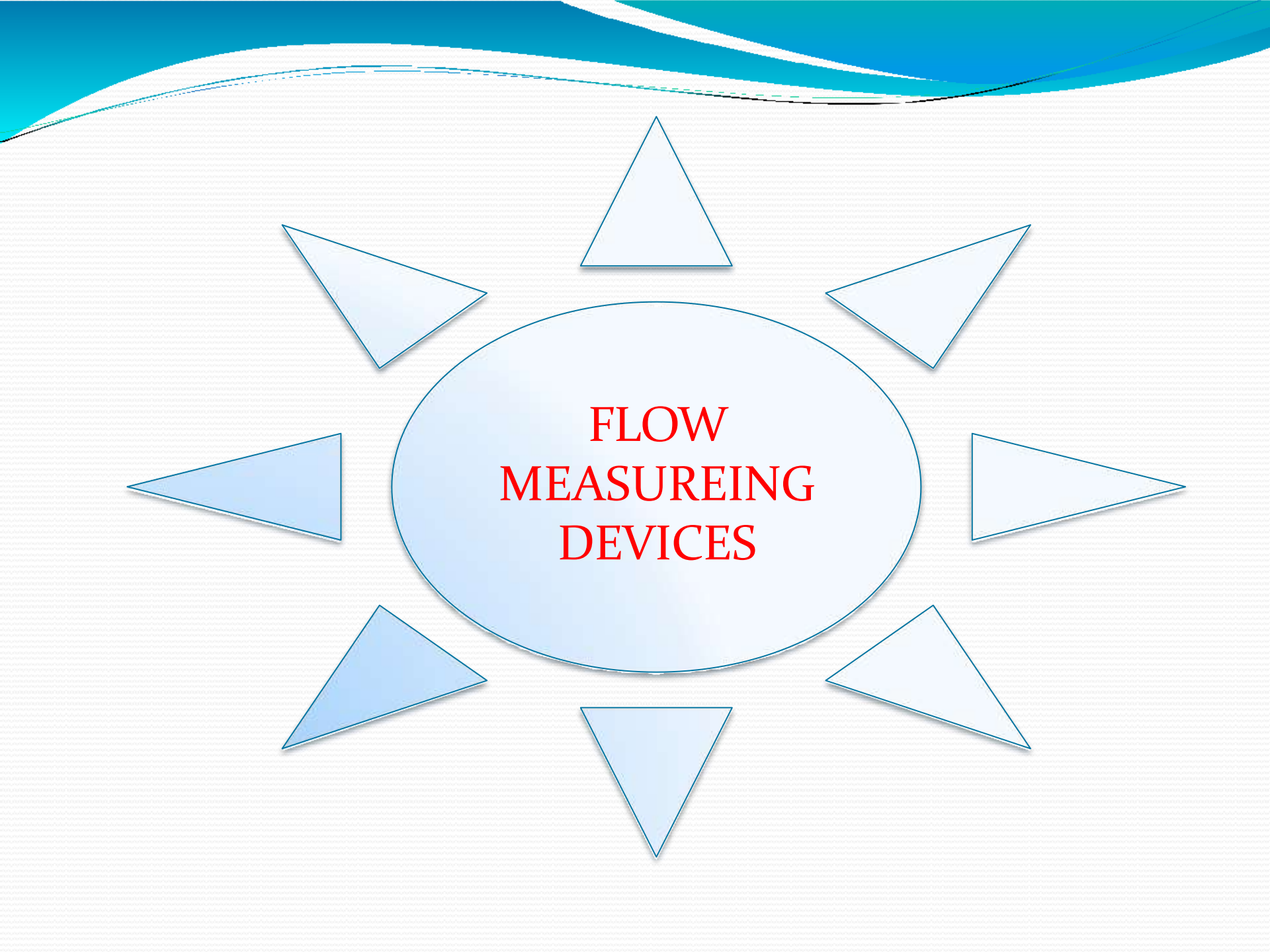

FLOW MEASUREING DEVICES

Orifice meter

An **Orifice Meter** is basically a type of flow **meter** used to measure the rate of flow of Liquid or Gas, especially Steam, using the Differential Pressure Measurement principle. It is mainly used for robust applications as it is known for its durability and is very economical.

An **orifice meter** is a conduit and a restriction to create a pressure drop. An hour glass is a form of orifice. A nozzle, venturi or thin sharp edged orifice can be used as the flow restriction.

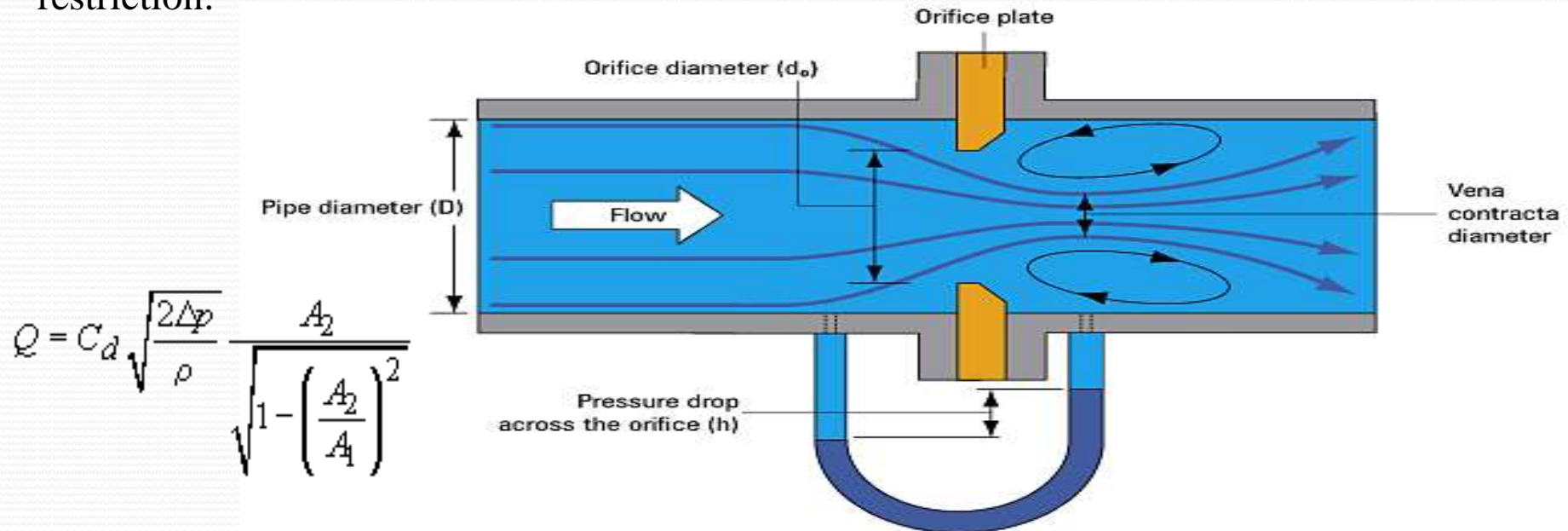

ORIFICE PLATES

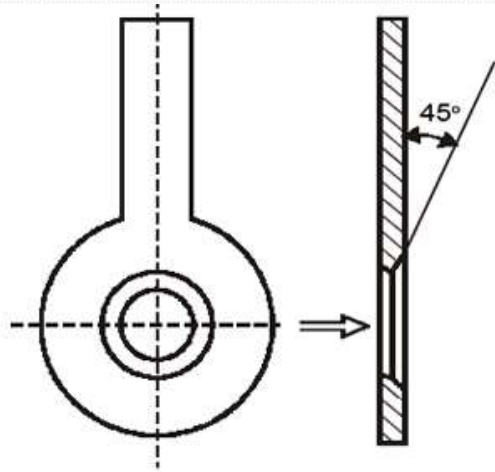

Concentric orifice plate

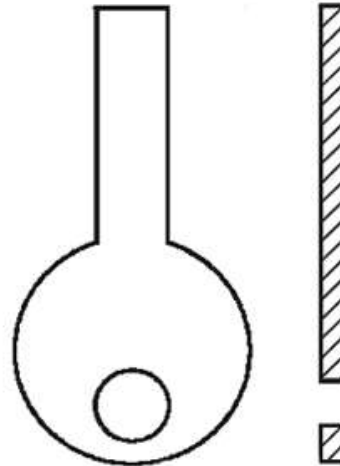

Eccentric orifice plate

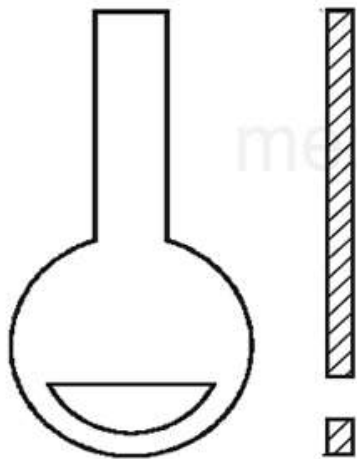

Segmental orifice plate

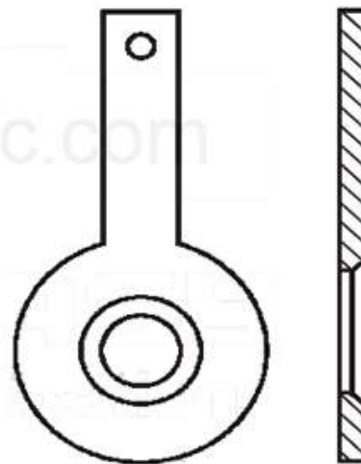

Quadrant edge orifice



Venturies

A **venturimeter** is a device used to measure the fluid flow through pipes. This flow measurement device is based on the principle of Bernoulli's equation. Inside the pipe, pressure difference is created by reducing the cross-sectional area of the flow passage. Bernoulli's **principle** states that with the increase in the velocity of the fluid its pressure decreases (or) decreases the fluid potential energy. Decreasing the fluid pressure in the areas where flow velocity is increased is called as Bernoulli effect.

The main parts of a venturimeter are:

A short converging part: It is that portion of the venturi where the fluid gets converges.

Throat: It is the portion that lies in between the converging and diverging **part** of the venturi.

Diverging part: It is the portion of the **venturimeter** (venturi) where the fluid gets diverges.

$$Q = C_d A_1 \sqrt{\frac{2gH}{\left(\frac{D_1}{D_2}\right)^2 - 1}}$$

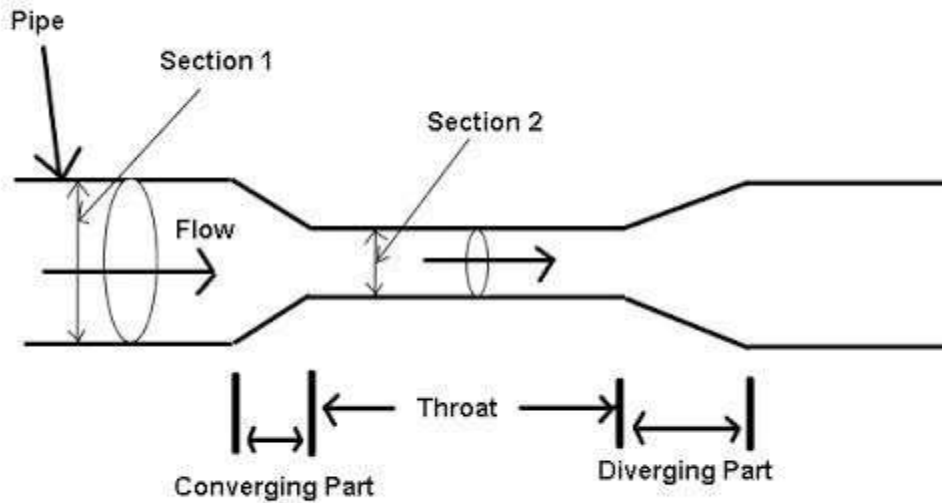

Venturimeter

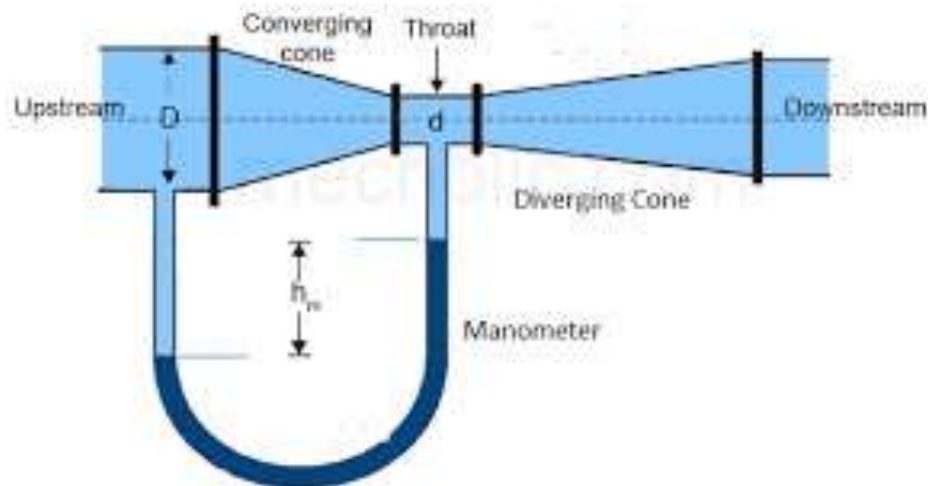

NOZZLE FLOW METER

A **flow nozzle meter** consists of a short **nozzle**, usually held in place between two pipe flanges as shown in the diagram at the left.. It is simpler and less expensive than a **venturi meter**, but not as simple as an **orifice meter**. ... A typical **flow nozzle** discharge coefficient value is between 0.93 and 0.98.

OPERATIONS:-

1. The fluid whose flow rate is to be measured enters the nozzle smoothly to the section called throat where the area is minimum.
2. Before entering the nozzle, the fluid pressure in the pipe is p_1 . As the fluid enters the nozzle, the fluid converges and due to this its pressure keeps on reducing until it reaches the minimum cross section area called throat. This minimum pressure p_2 at the throat of the nozzle is maintained in the fluid for a small length after being discharged in the down stream also.
3. The differential pressure sensor attached between points 1 and 2 records the pressure difference ($p_1 - p_2$) between these two points which becomes an indication of the flow rate of the fluid through the pipe when calibrated.

Flow nozzle

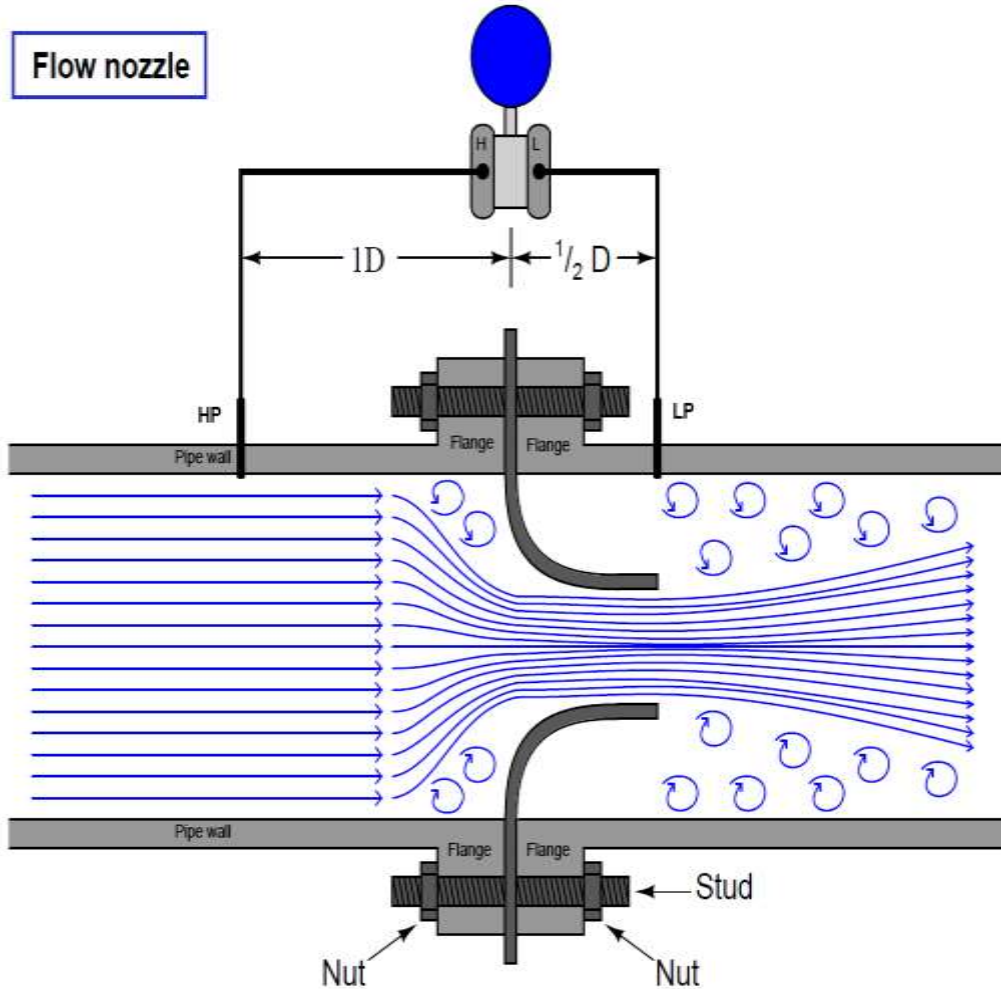

Applications of Flow Nozzle:-

- ❖ It is used to measure flow rates of the liquid discharged into the atmosphere.
- ❖ It is usually used in situation where suspended solids have the property of settling.
- ❖ It is widely used for high pressure and temperature steam flows.

Advantages of flow Nozzle:-

- ✓ Installation is easy and is cheaper when compared to venturi meter
- ✓ It is very compact
- ✓ Has high coefficient of discharge.

Disadvantages of flow Nozzle:-

- Pressure recovery is low
- Maintenance is high
- Installation is difficult when compared to orifice flow meter.

ROTA-METER

A **rotameter** is a device that measures the volumetric flow rate of fluid in a closed tube. It belongs to a class of **meters** called variable area **meters**, which measure flow rate by allowing the cross-sectional area the fluid travels through to vary, causing a measurable effect.

It works on the principle of upthrust force exerted by fluid and force of gravity. The buoyant force exerted on an immersed object is equal to the weight of liquid displaced by the object. Under this principle, the rotameter works with float-tapered tube system.

WORKING:-

Fluid enters from the bottom of the tapered tube, then some of the fluid strikes directly into the float bottom and others pass aside the float. Now the float experience two forces in opposite direction, drag force upward and gravitational force downward.

Fluid flow moves the float upward against gravity. At some point, the flowing area reaches a point where the pressure-induced force on the floating body exactly matches the weight of the float. The float will find equilibrium when the area around float generates enough drag equal to weight - buoyancy.

As the float weight and gravity are constant, the distance float displaced upward is proportional to the flow velocity of the fluid passing through the tapered tube.

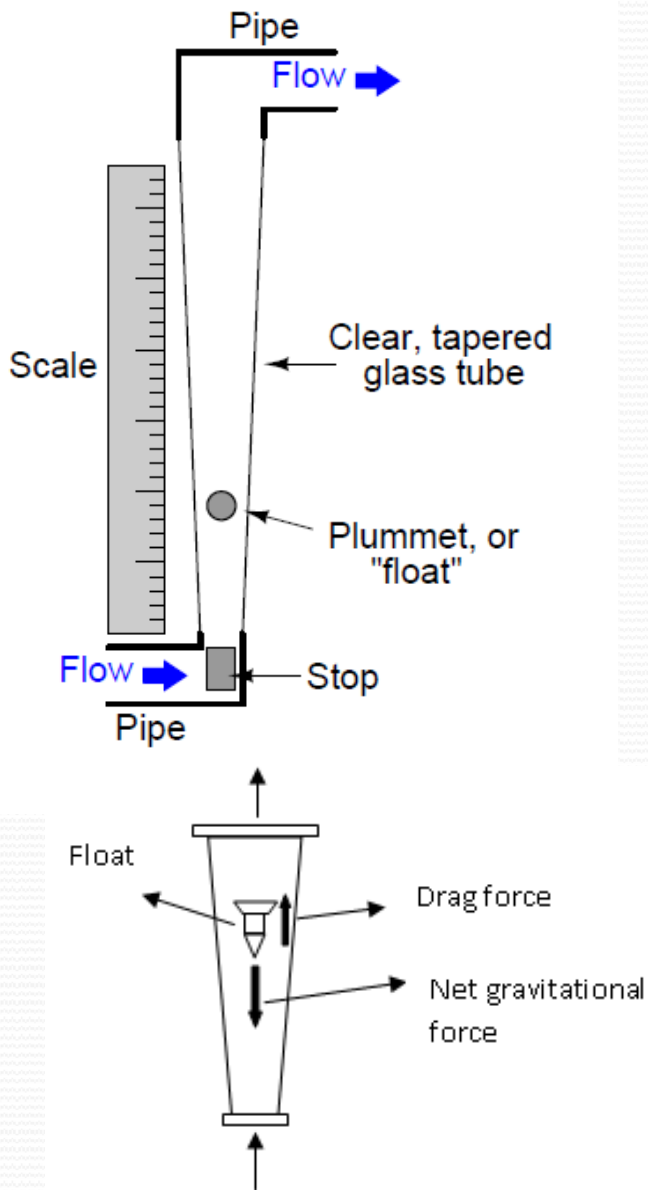

Advantages:

- ✓ No external power needed
- ✓ Simple Reliable Design
- ✓ Can Measure Liquid or Gas Flows
- ✓ Scale is approximately linear
- ✓ It can measure flow rates of corrosive fluid
- ✓ Better rangeability
- ✓ Low cost and low pressuredrop

Disadvantages:

- It should be mounted vertically
- And requires lining mounting
- Uncertainty of measurement
- Difficult to handle the glasstype





THANK YOU

Disclaimer:- All the images and contain used from the Google and other website for the educational purpose not for commercial. This presentation used to teach students only.